

Kitchener 3 40 (575x760)

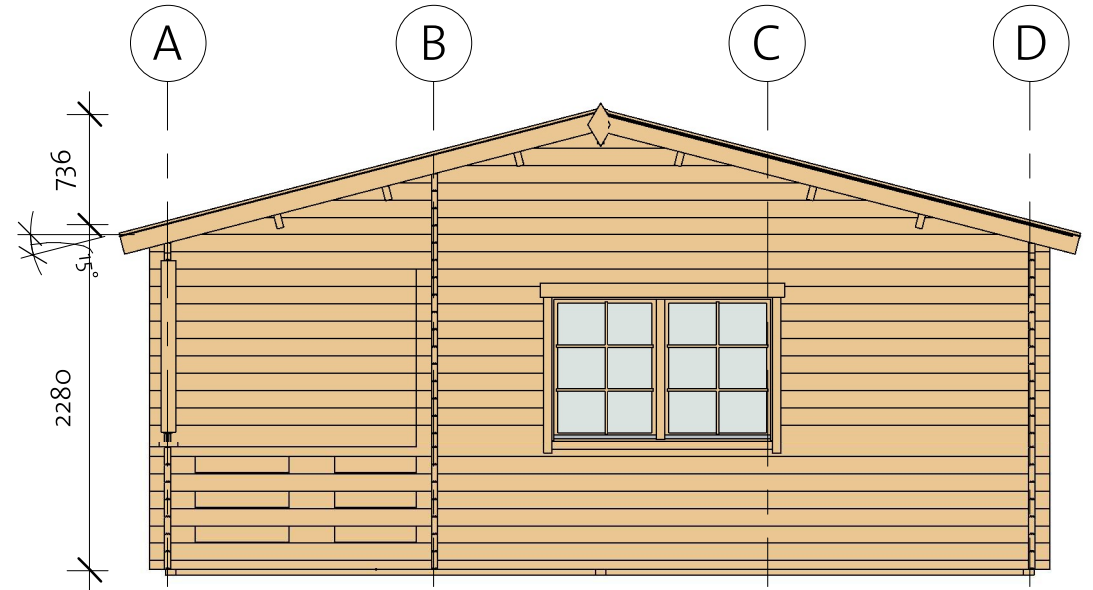
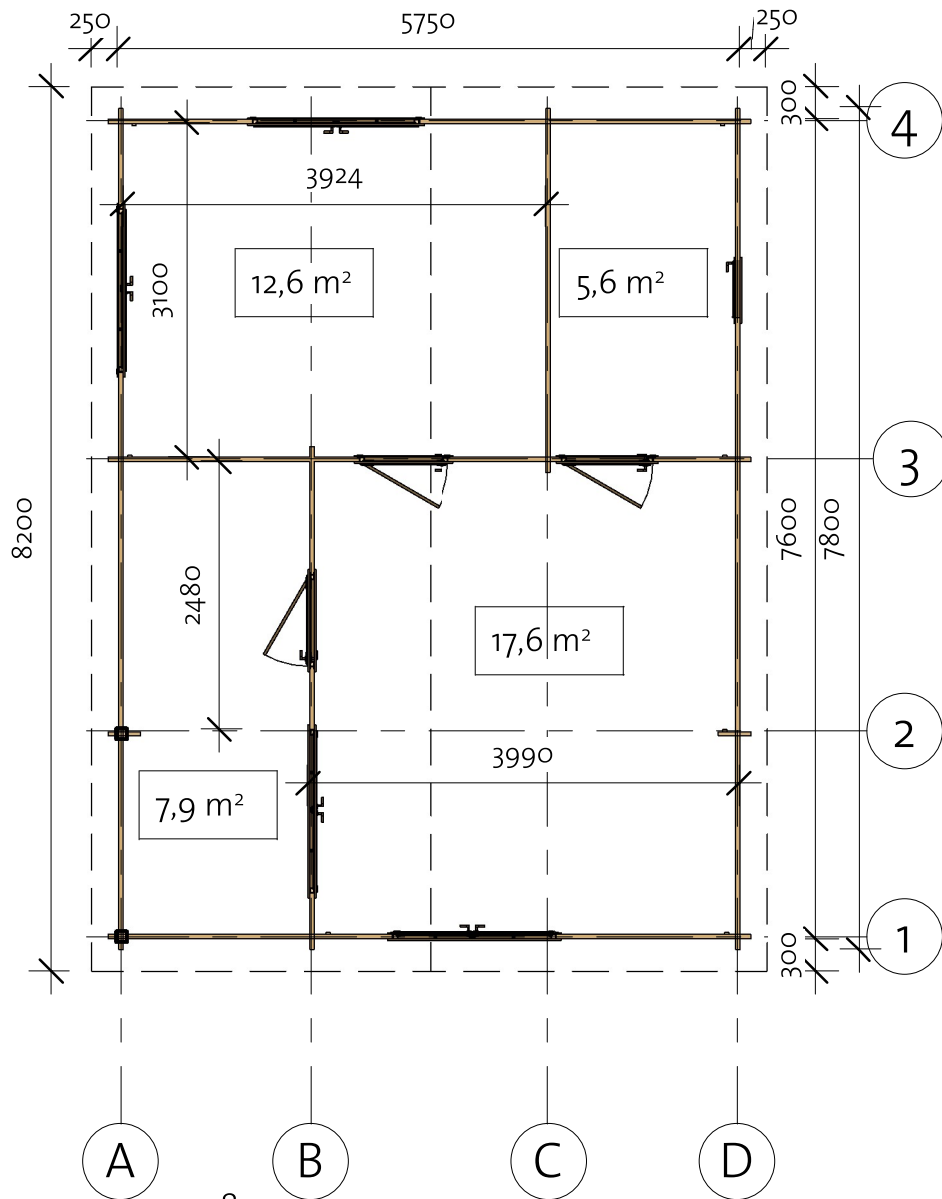

92402292_240308

 **VIKTRÄ**

Kitchener 3 40 (575x760)

Foundation

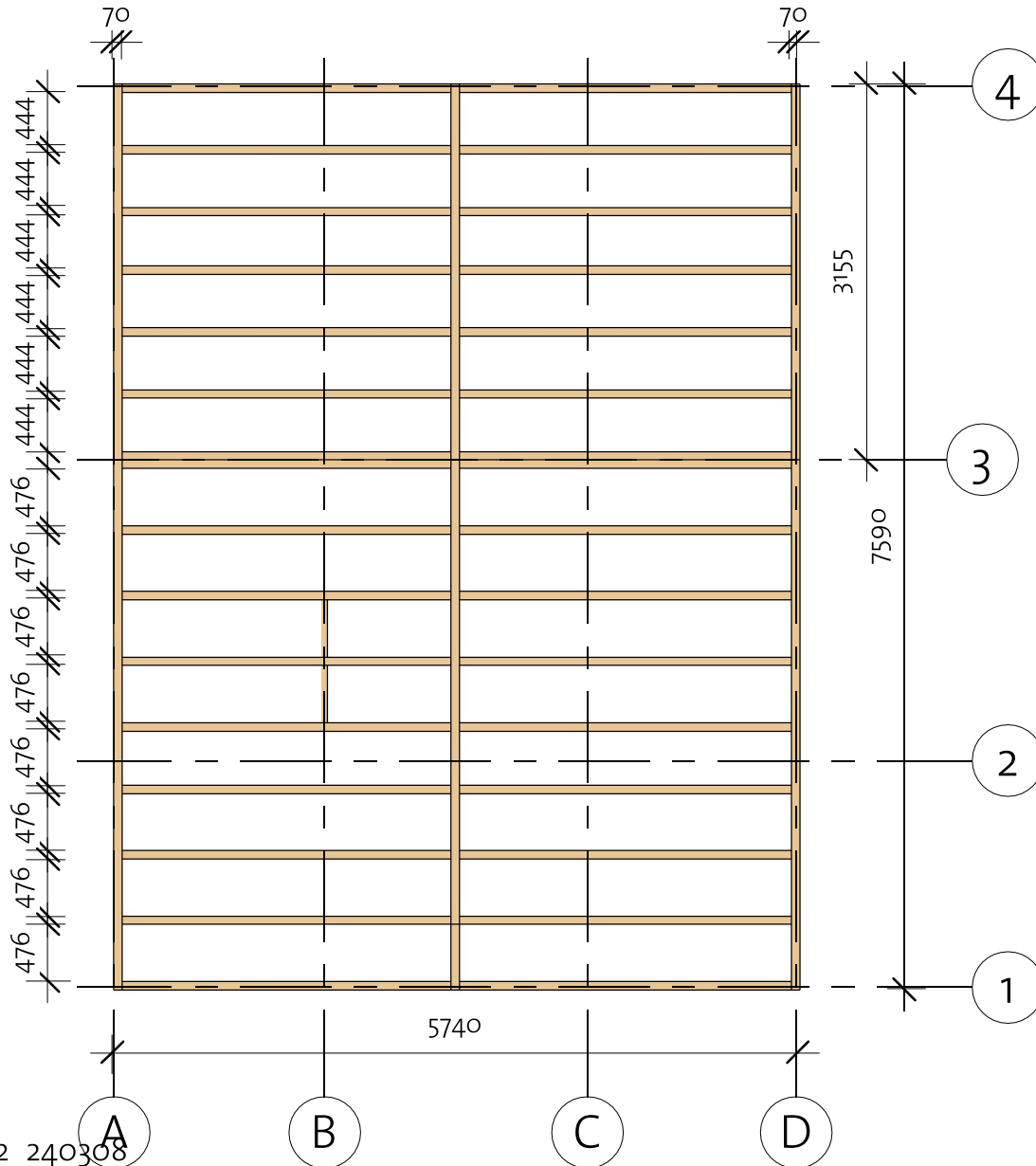

Impregnated foundation beams				
Mark	Type	Profile	Count	Length



IFB1	IFB 70x40		32	2765
IFB2	IFB 70x40		3	4435
IFB3	IFB 70x40		3	3155
IFB4	IFB 70x40		2	476

Kitchener 3 40 (575x760)

Floor Plan

Floor Schedule

Mark	Type	Profile	Count	Length
------	------	---------	-------	--------

FB1	FB 17x114		35	4374
FB2	FB 17x114		50	3094
TB	TB 21x95		17	4375

BB 1	BB 18x40		5	3200
BB 2	BB 18x40		5	4400

① Baseboard

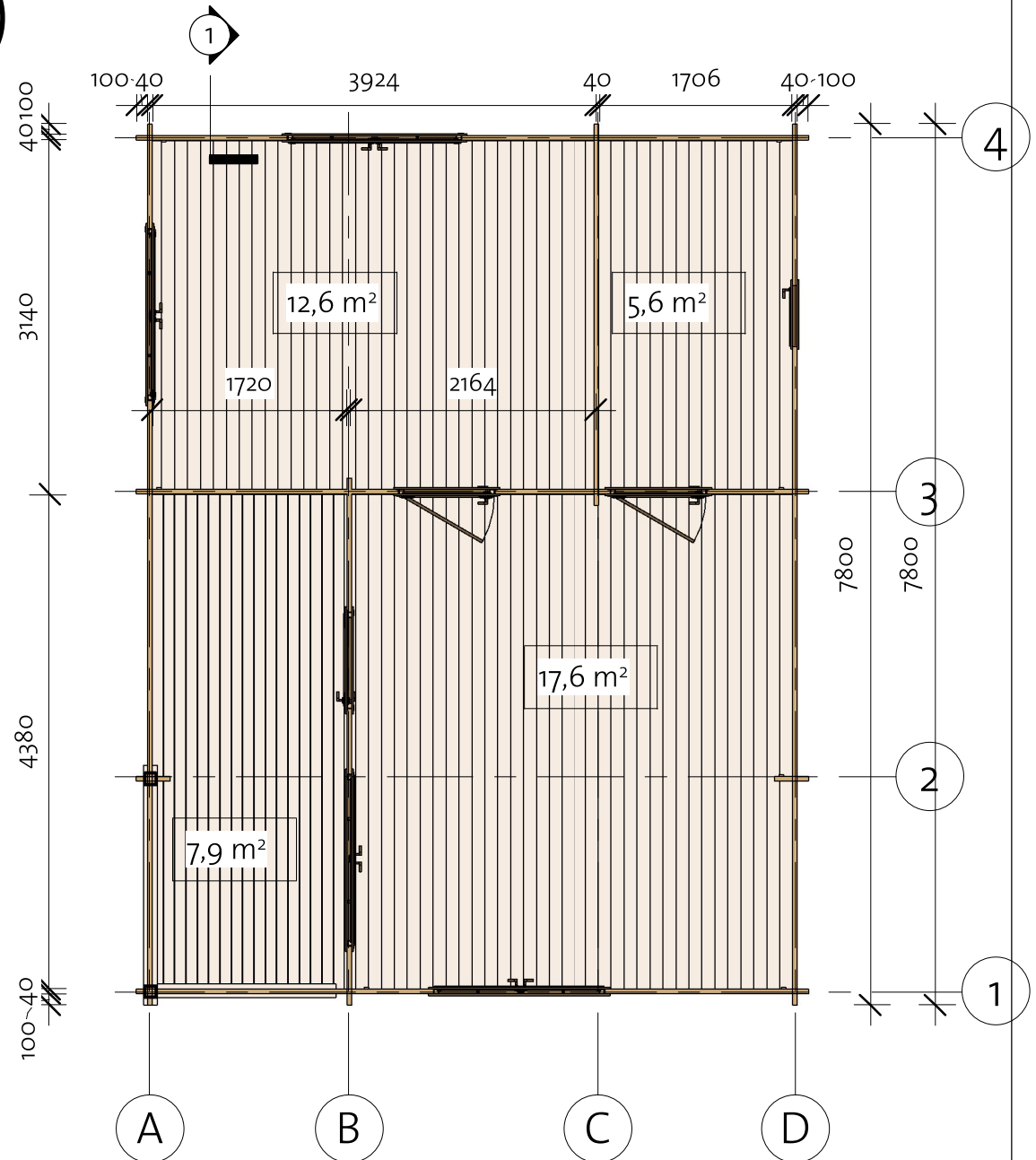
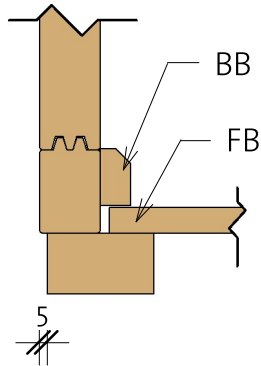

Kitchener 3 40 (575x760)

Wall 1

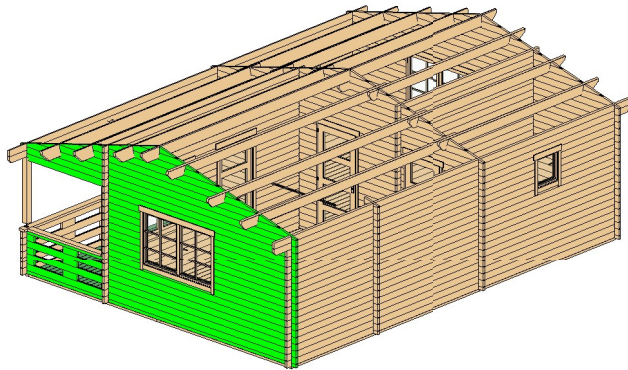

Log Profile Wall 1	
Profile	Profile

40x57	
-------	---

Log Profile Wall 1	
Profile	Profile

40x114	
--------	---

Wall 1			
Mark	Profile	Count	Cut Length

1BL-1	40x57	1	5950
1LG-1 *	40x114	1	837
1LG-2 *	40x114	1	1716
1LG-3 *	40x114	1	2594
1LG-4 *	40x114	1	3473
1LG-5 *	40x114	1	4277
1LG-6 *	40x114	1	5231
1LG-7 *	40x114	1	5950
1LG-8	40x114	1	5950
1LG-9	40x114	1	5950
1LG-10	40x114	4	4190
1LG-11	40x114	9	860
1LG-12	40x114	9	1790
1LG-13	40x114	1	5950
1LG-14	40x114	3	5950
1LG-15	40x114	3	300
1LG-16	40x114	3	300

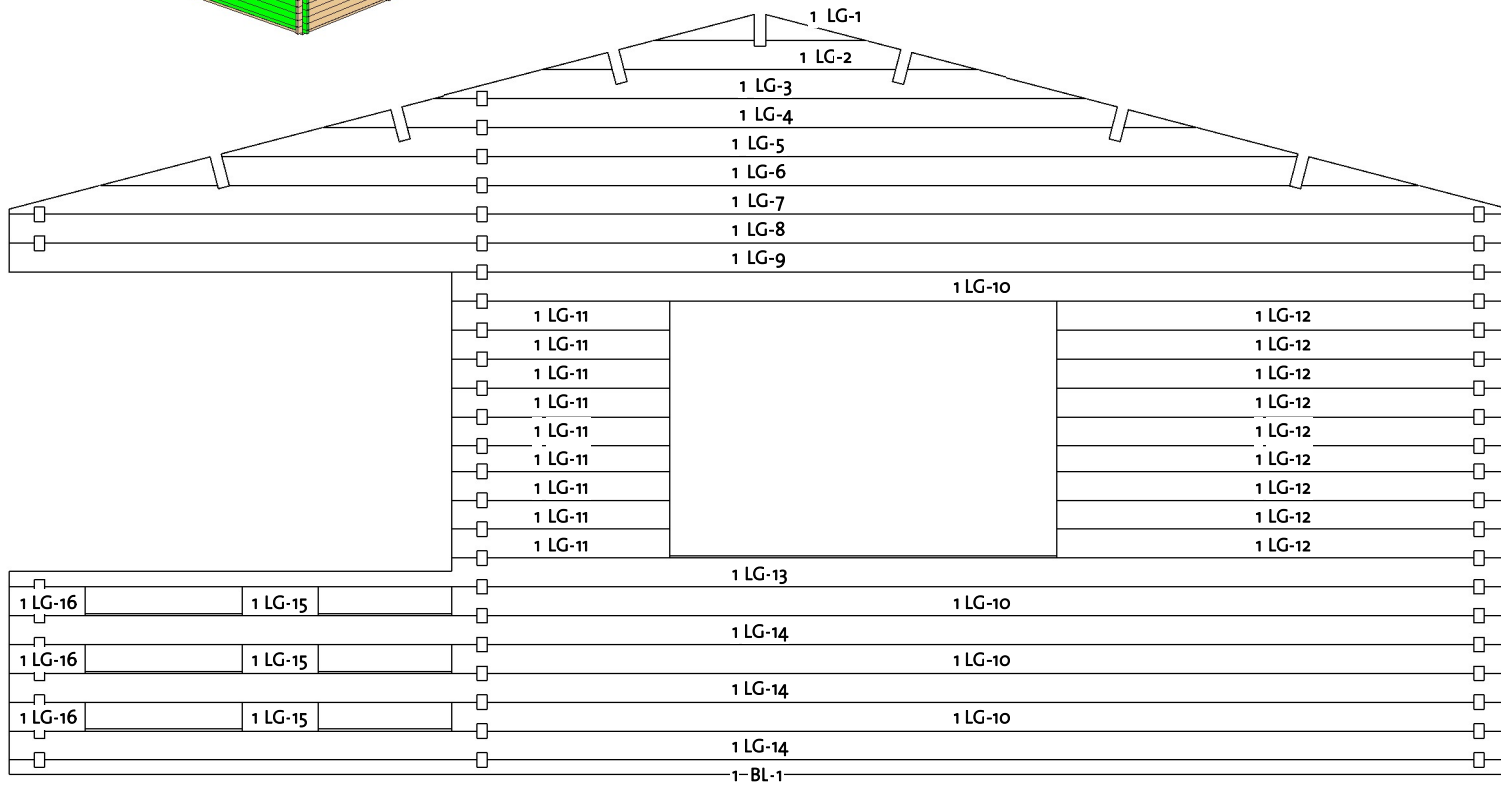

* Gable - delivered premounted

Kitchener 3 40 (575x760)

Wall 2

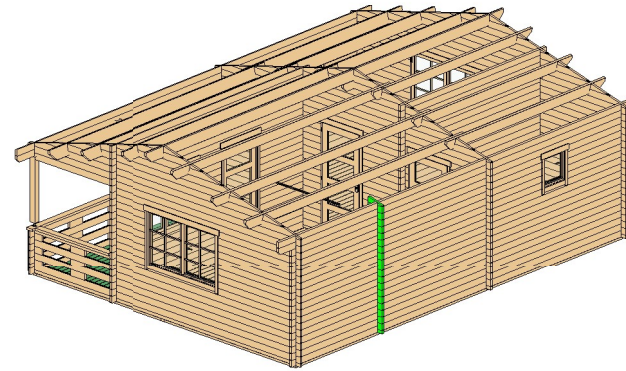

Wall 2			
Mark	Profile	Count	Cut Length

2BL-1	40x57	2	300
2LG-1	40x57	1	300
2LG-2	40x114	25	300
2LG-3	40x114	1	300

	2 LG-1
	2 LG-2
	2 LG-2
	2 LG-2
	2 LG-2
	2 LG-2
	2 LG-2
	2 LG-2
	2 LG-2
	2 LG-2
	2 LG-2
	2 BL-1

2 LG-3	
2 LG-2	
2 LG-2	
2 LG-2	
2 LG-2	
2 LG-2	
2 LG-2	
2 LG-2	
2 LG-2	
2 LG-2	
2 LG-2	
2 LG-2	
2 LG-2	
2 LG-2	
2 LG-2	
2 LG-2	
2 LG-2	
2 LG-2	
2 LG-2	
2 LG-2	
2 LG-2	
2 LG-2	
2 LG-2	
2 BL-1	

Log Profile Wall 2	
Profile	Profile

40x57	
40x57	

Kitchener 3 40 (575x760)

Wall 3

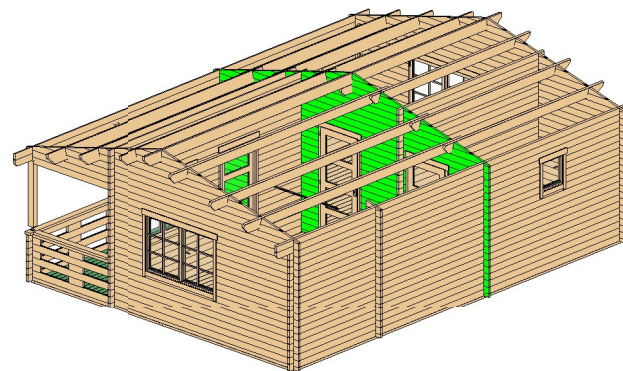

Wall 3			
Mark	Profile	Count	Cut Length

3BL-1	40x57	1	2314
3BL-2	40x57	1	1040
3BL-3	40x57	1	896
3LG-1*	40x114	1	837
3LG-2*	40x114	1	1716
3LG-3*	40x114	1	2594
3LG-4*	40x114	1	3473
3LG-5*	40x114	1	4277
3LG-6*	40x114	1	5231
3LG-7*	40x114	1	5950
3LG-8	40x114	2	5950
3LG-9	40x114	17	2314
3LG-10	40x114	17	1040
3LG-11	40x114	17	896

* Gable - delivered premounted

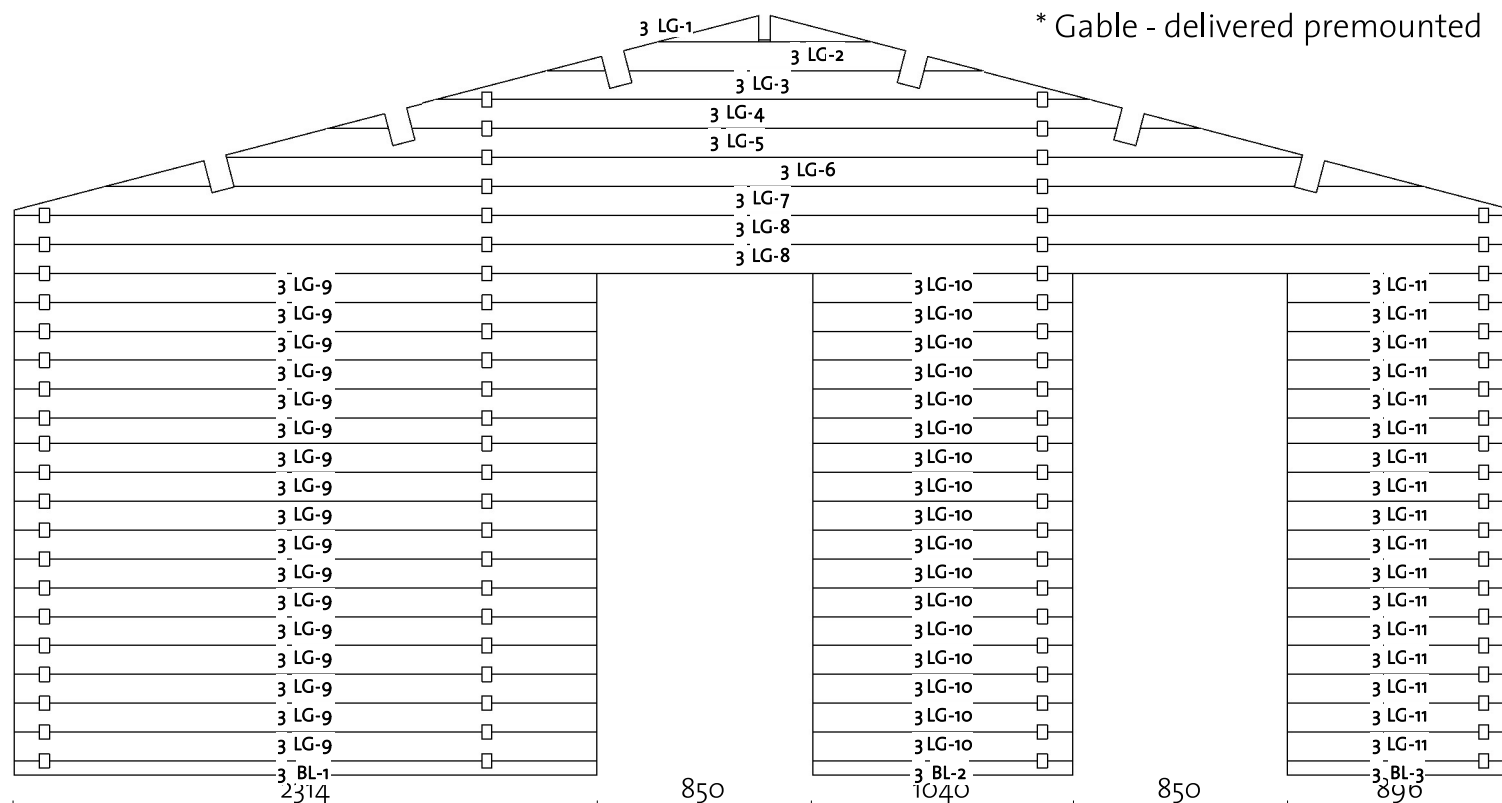

Log Profile Wall 3	
Profile	Profile

40x57	
40x57	

92402292_240308

Kitchener 3 40 (575x760)

Wall 4

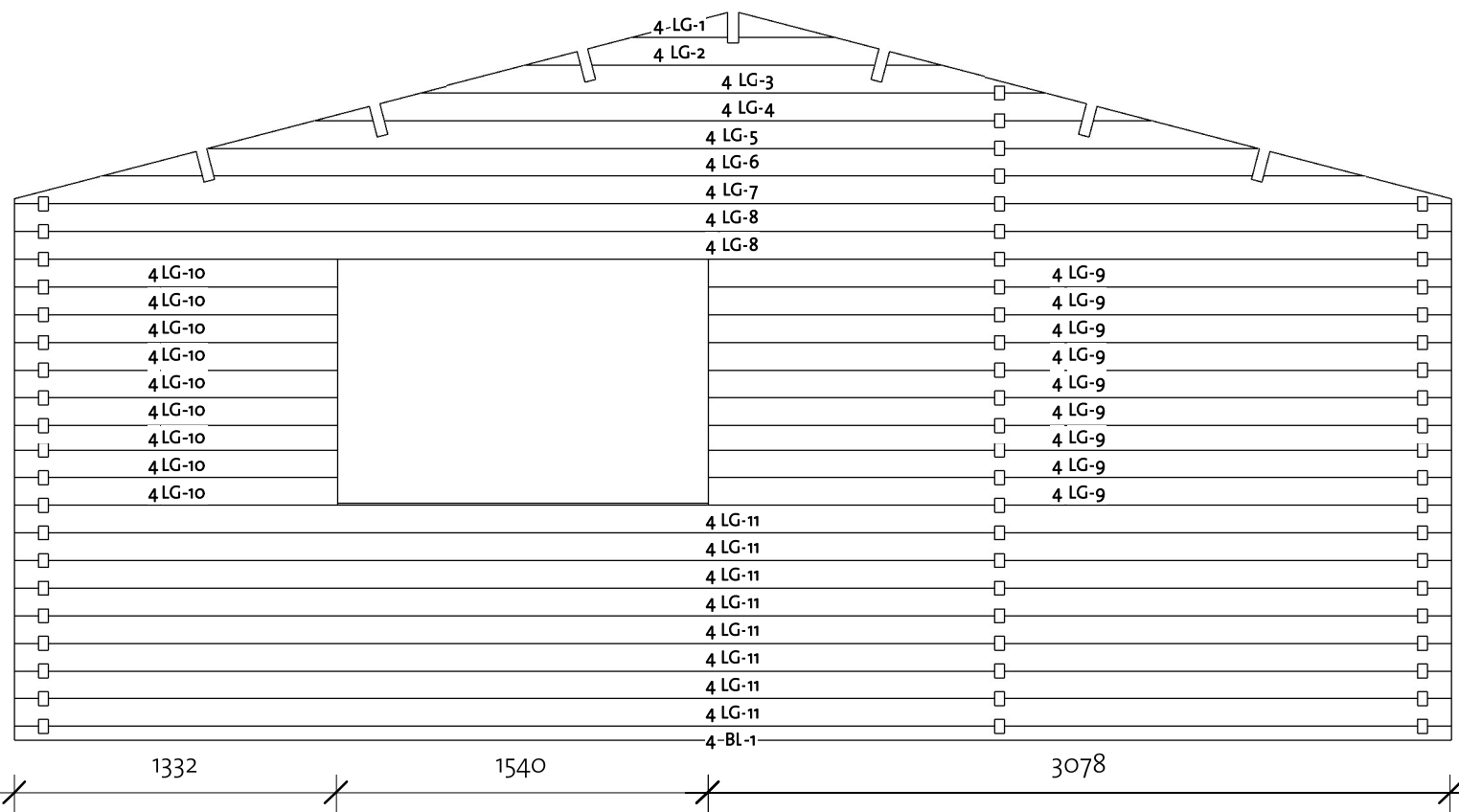
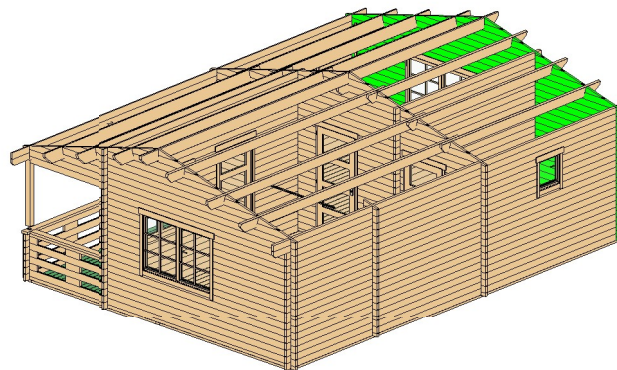

Wall 4			
Mark	Profile	Count	Cut Length

4BL-1	40x57	1	5950
4LG-1*	40x114	1	837
4LG-2*	40x114	1	1716
4LG-3*	40x114	1	2594
4LG-4*	40x114	1	3473
4LG-5*	40x114	1	4352
4LG-6*	40x114	1	5231
4LG-7*	40x114	1	5950
4LG-8	40x114	2	5950
4LG-9	40x114	9	3078
4LG-10	40x114	9	1332
4LG-11	40x114	8	5950

* Gable - delivered premounted

Log Profile Wall 4	
Profile	Profile

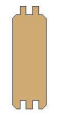
40x57	
40x114	

92402292_240308

Kitchener 3 40 (575x760)

Wall A

Log Profile Wall A	
Profile	Profile

Log Profile Wall A	
Profile	Profile

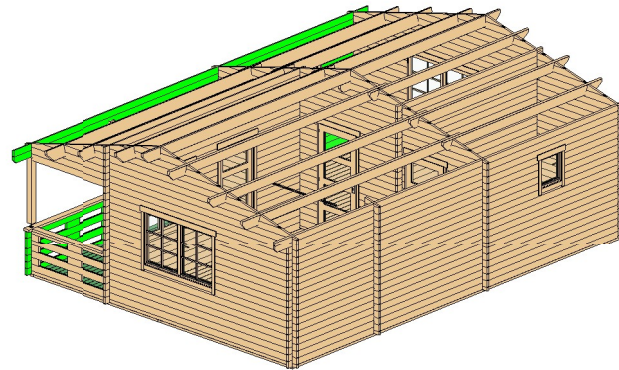
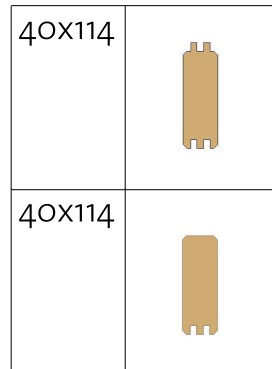
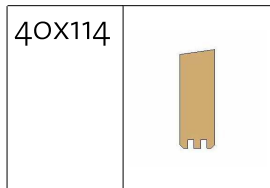

Wall A			
Mark	Profile	Count	Cut Length

ALG-1	40X114	1	3460
ALG-2	40X114	1	4840
ALG-3	40X114	1	1020
ALG-4	40X114	17	920
ALG-5	40X114	9	3380
ALG-6	40X114	6	300
ALG-7	40X114	3	300
ALG-8	40X114	1	2140
ALG-9	40X114	3	2140
ATL-1	40X114	1	3460
ATL-2	40X114	1	4840

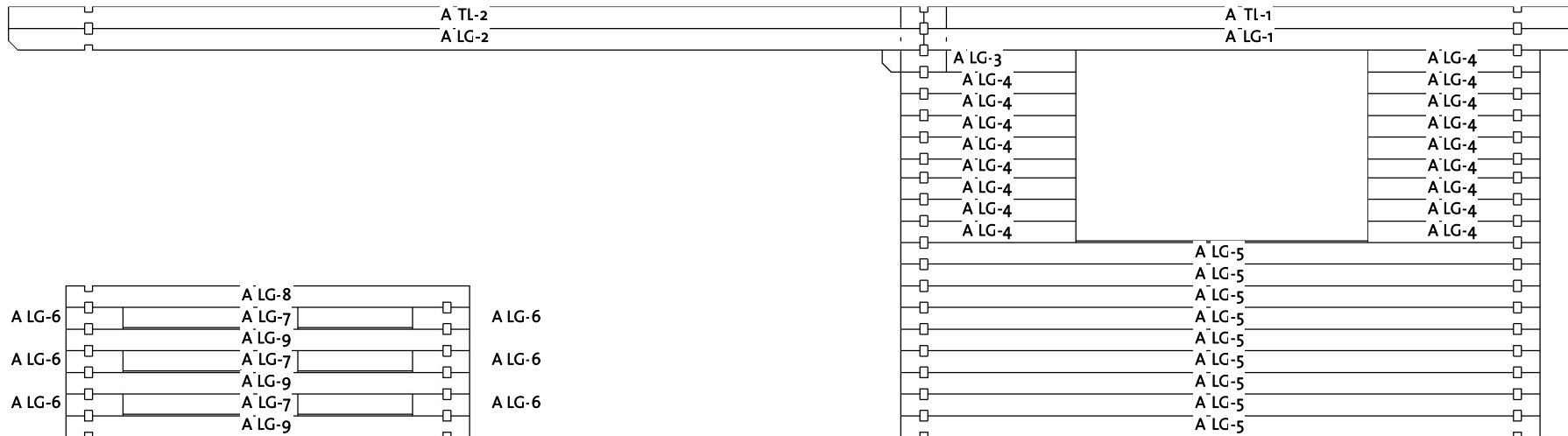

92402292_240308

Kitchener 3 40 (575x760)

Wall B

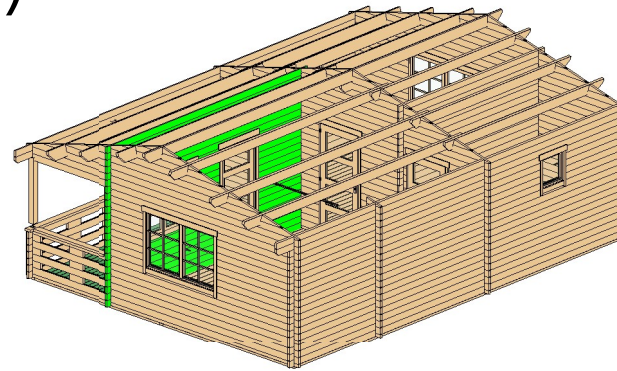

Wall B			
Mark	Profile	Count	Cut Length

BLG-1	40X114	9	575
BLG-2	40X114	5	4660
BLG-3	40X114	9	520
BLG-4	40X114	17	1175
BLG-5	40X114	1	4660
BLG-6	40X114	8	2635
BTL-1	40X114	1	4660

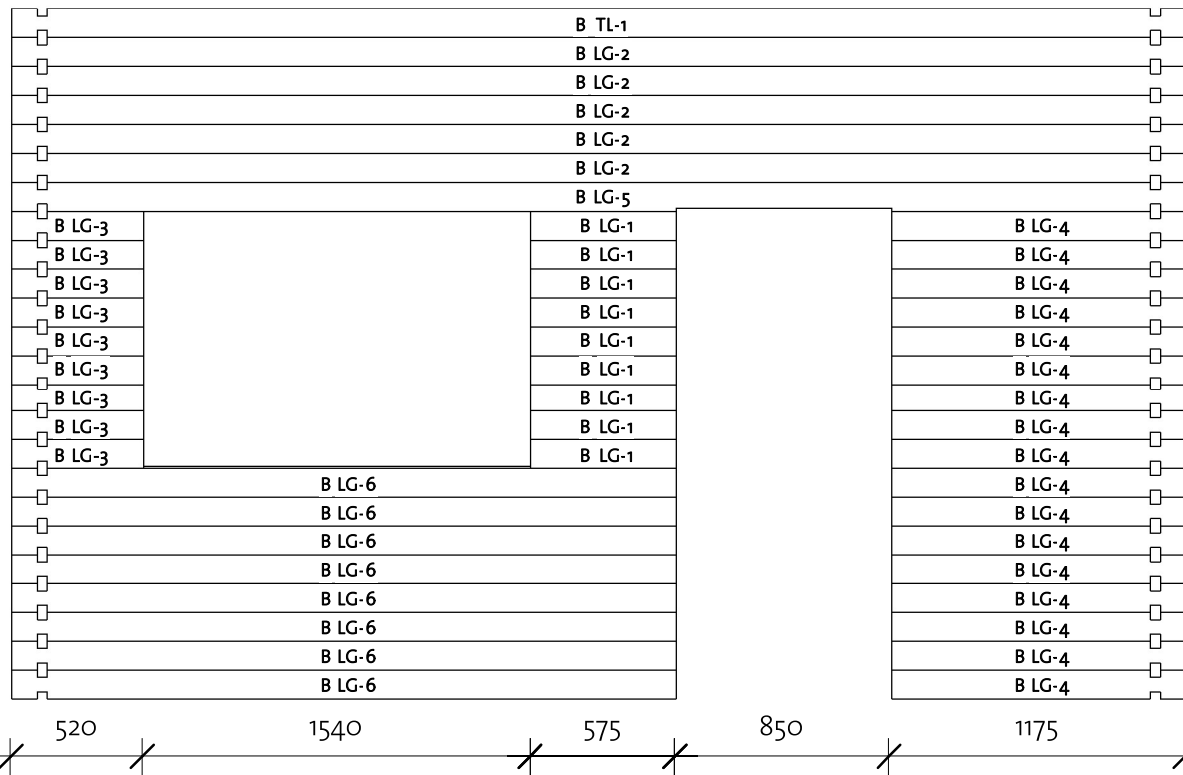

Log Profile Wall B	
Profile	Profile

40X114	
40X114	

Kitchener 3 40 (575x760)

Wall D

Log Profile Wall D	
Profile	Profile

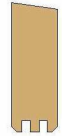
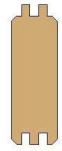
40X114	
40X114	

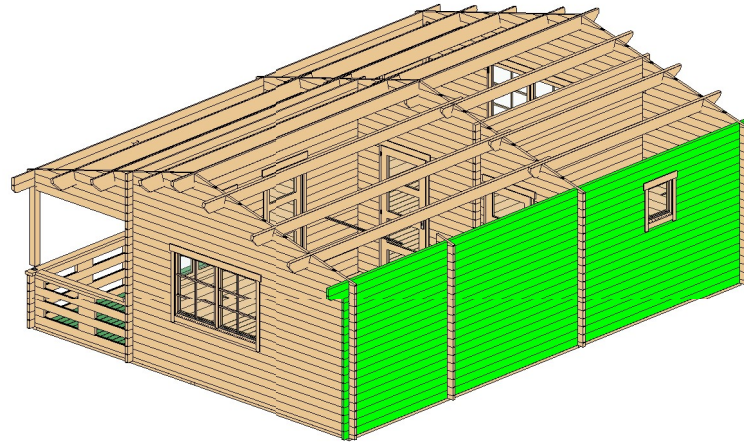

Wall D

Mark	Profile	Count	Cut Length
------	---------	-------	------------

DLG-1	40X114	1	4840
DLG-2	40X114	7	2020
DLG-3	40X114	5	5838
DLG-4	40X114	5	1418
DLG-5	40X114	6	3260
DLG-6	40X114	7	5780
DLG-7	40X114	6	4540
DLG-8	40X114	1	3460
DTL-1	40X114	1	5980
DTL-2	40X114	1	2320

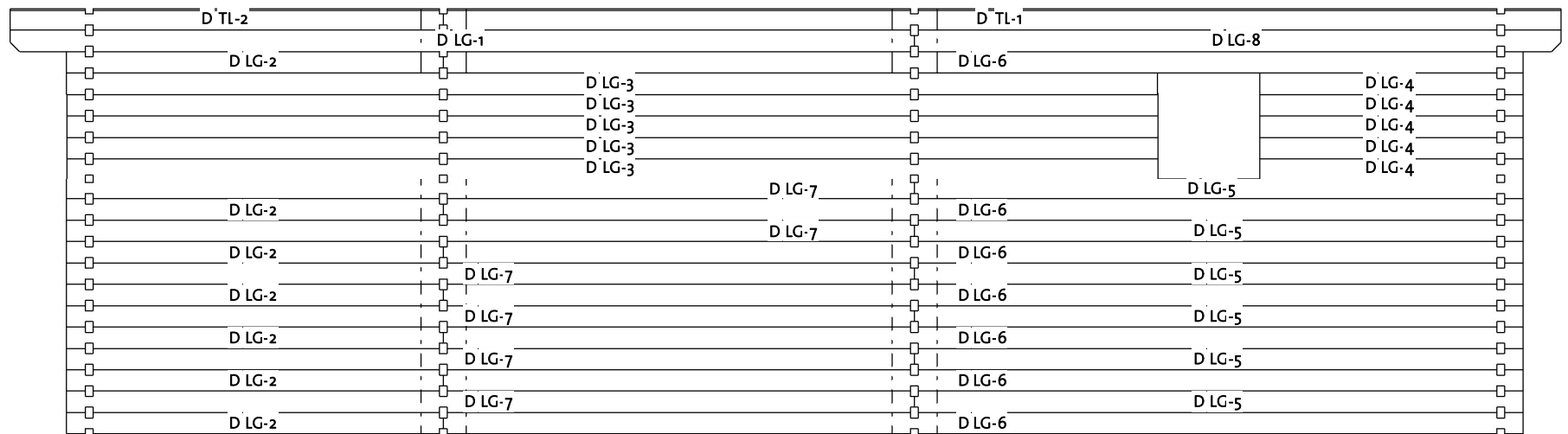

92402292_240308

Kitchener 3 40 (575x760)

Roof 1

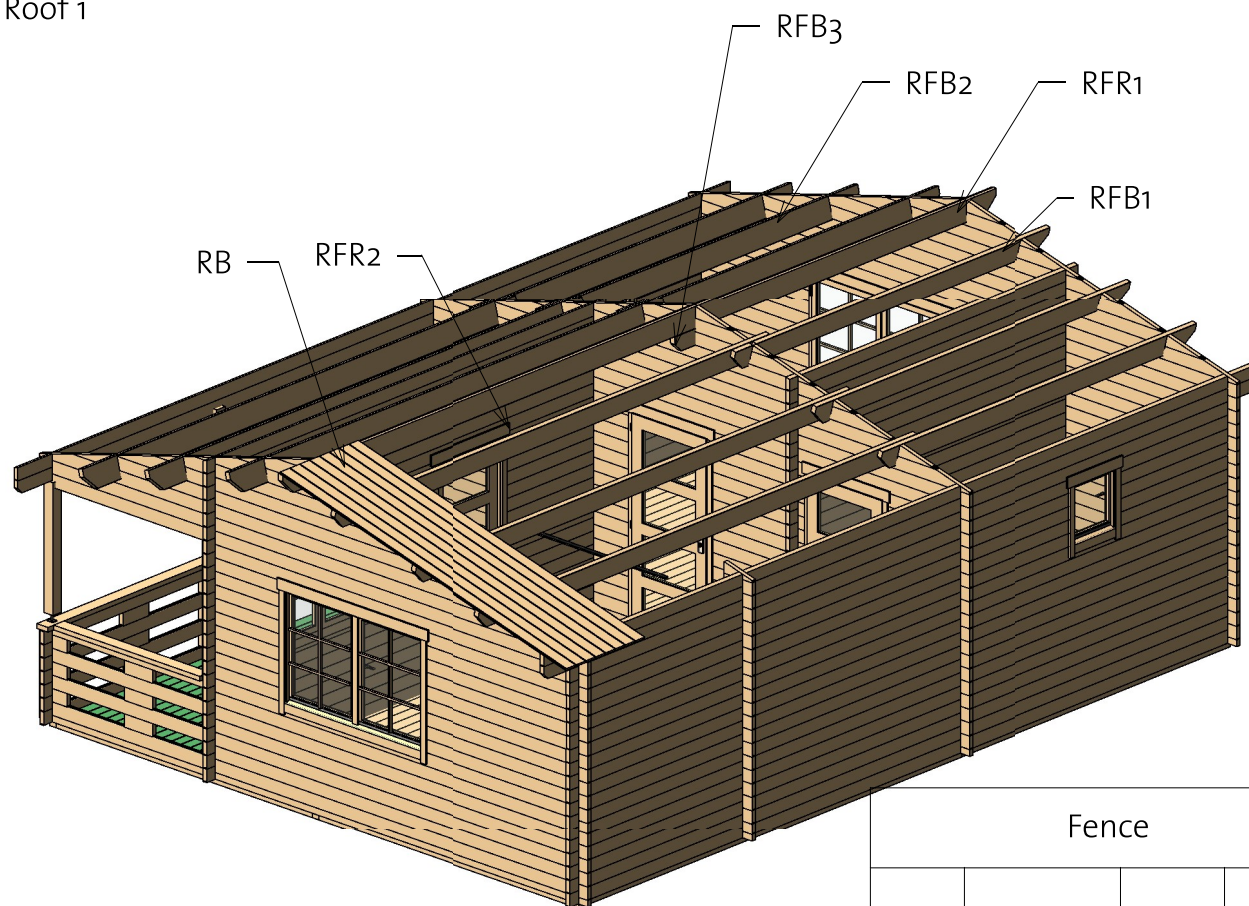

Columns			
Mark	Profile	Count	Length

CM1	Post 80x70	1	1129
CM2	Post 80x70	1	1184

Fence			
Mark	Type	Count	Cut Length

FN1	Fence 40x120	1	2140
FN2	Fence 40x120	1	1575

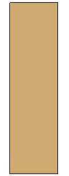
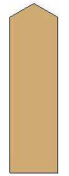
Roof				
Mark	Type	Profile	Count	Cut Length
RB	17x114		148	3223
RFB1	Beam 45x195		6	5060
RFB2	Beam 45x195		6	3680
RFB3	Beam 45x143		1	520
RFR1	Ridge 45x195		1	3460
RFR2	Ridge 45x195		1	4840

Kitchener 3 40 (575x760)

Roof 2

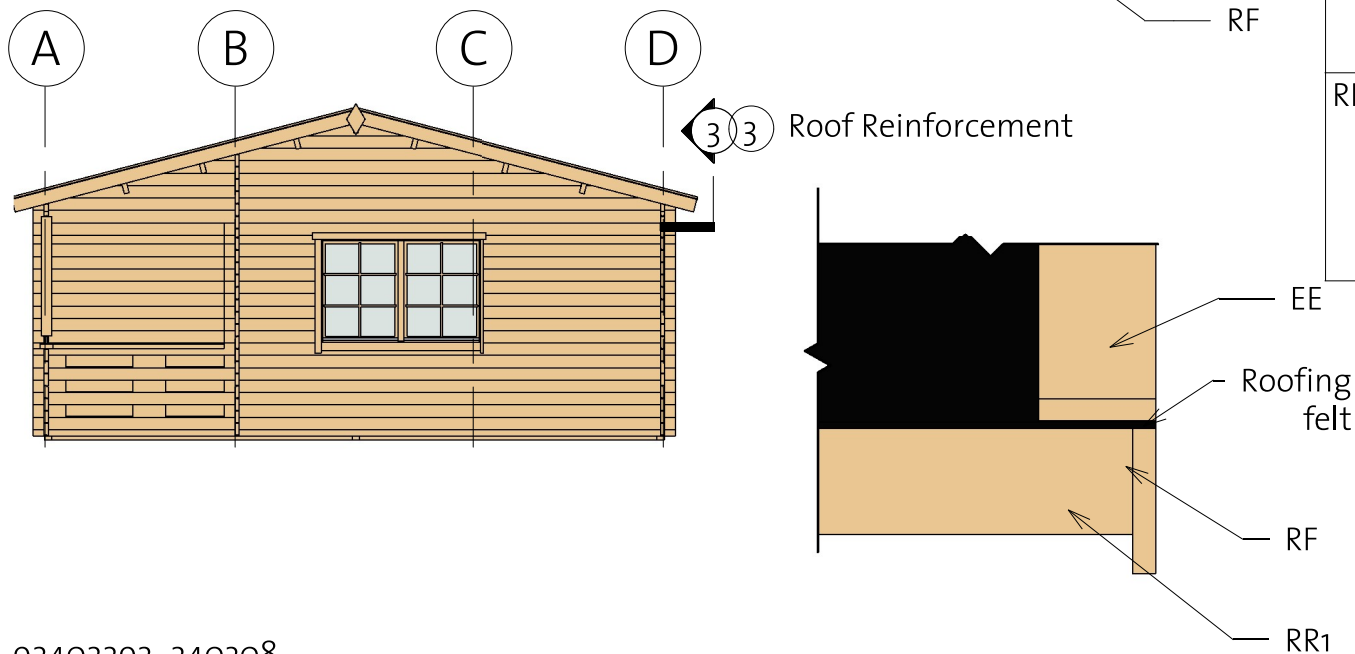
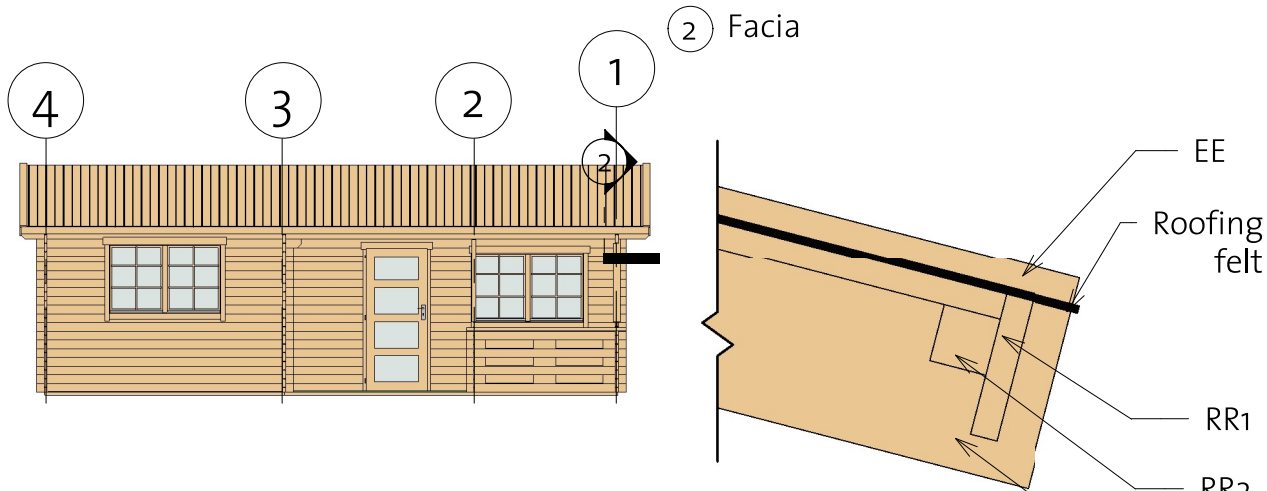

Fascia Schedule				
Mark	Type	Profile	Count	Length
EE	Eave Edging 18x95		4	3274
RF	Roof Fascia 18x120		4	3274
RR1	Roof reinforcement 18x95		4	4150
RR2	Roof reinforcement 38x38		4	4150

Kitchener 3 40 (575x760)

Extras

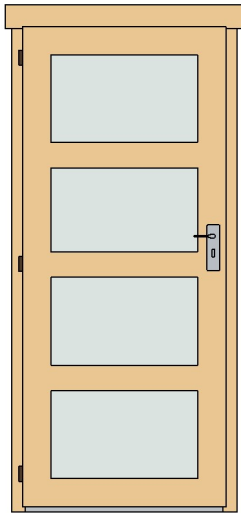

Door Schedule				
Model	Type	Width	Height	Count
CD2L	Classic door 2, four glass left	840	1955	3

Type	Count	Length
Windboard 18x40	7	2200

Type	Count
Romb	2

Fasteners/Extras		
Name	Type	Count

Hitblock	300-400 mm	
Bolts	M8x70	21
Dowel	16,0 x 150	46
Screws	5,0 x 70	50
Nails	1,4 x 40	80
Screws	6,0 x 140	170
Screws	4,0 x 40	1640

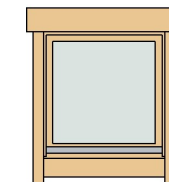
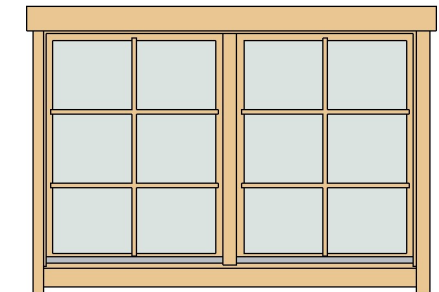

Window Schedule				
Model	Type	Width	Height	Count
CDW1	Classic double window 1	1530	990	4
CW12R	Classic window 12, full glass righth	540	540	1
WCB6	Window Crossbar 6			8



Kitchener 3 40 (575x760)



List of all items 1

Impregnated foundation beams				
Mark	Type	Profile	Count	Length
IFB1	IFB 70x40		32	2765
IFB2	IFB 70x40		3	4435
IFB3	IFB 70x40		3	3155
IFB4	IFB 70x40		2	476

Floor Schedule				
Mark	Type	Profile	Count	Length
FB1	FB 17x114		35	4374
FB2	FB 17x114		50	3094
TB	TB 21x95		17	4375

BB 1	BB 18x40		5	3200
BB 2	BB 18x40		5	4400

92402292_240308





Roof				
Mark	Type	Profile	Count	Cut Length
RB	17x114		148	3223
RFB1	Beam 45x195		6	5060
RFB2	Beam 45x195		6	3680
RFB3	Beam 45x143		1	520
RFR1	Ridge 45x195		1	3460
RFR2	Ridge 45x195		1	4840

Columns			
Mark	Profile	Count	Length
CM1	Post 80x70	1	1129
CM2	Post 80x70	1	1184

Fence			
Mark	Type	Count	Cut Length
FN1	Fence 40x120	1	2140
FN2	Fence 40x120	1	1575

Kitchener 3 40 (575x760)

List of all items 2

Fascia Schedule				
Mark	Type	Profile	Count	Length
EE	Eave Edging 18x95		4	3274
RF	Roof Fascia 18x120		4	3274
RR1	Roof reinforcement 18x95		4	4150
RR2	Roof reinforcement 38x38		4	4150

Wall 1			
Mark	Profile	Count	Cut Length

1BL-1	40x57	1	5950
1LG-1 *	40x114	1	837
1LG-2 *	40x114	1	1716
1LG-3 *	40x114	1	2594
1LG-4 *	40x114	1	3473
1LG-5 *	40x114	1	4277
1LG-6 *	40x114	1	5231
1LG-7 *	40x114	1	5950
1LG-8	40x114	1	5950
1LG-9	40x114	1	5950
1LG-10	40x114	4	4190
1LG-11	40x114	9	860
1LG-12	40x114	9	1790
1LG-13	40x114	1	5950
1LG-14	40x114	3	5950
1LG-15	40x114	3	300
1LG-16	40x114	3	300

Wall 2			
Mark	Profile	Count	Cut Length

2BL-1	40x57	2	300
2LG-1	40x57	1	300
2LG-2	40x114	25	300
2LG-3	40x114	1	300

* Gable - delivered premounted

Kitchener 3 40 (575x760)

List of all items 3

Wall 3			
Mark	Profile	Count	Cut Length

3BL-1	40X57	1	2314
3BL-2	40X57	1	1040
3BL-3	40X57	1	896
3LG-1 *	40X114	1	837
3LG-2 *	40X114	1	1716
3LG-3 *	40X114	1	2594
3LG-4 *	40X114	1	3473
3LG-5 *	40X114	1	4277
3LG-6 *	40X114	1	5231
3LG-7 *	40X114	1	5950
3LG-8	40X114	2	5950
3LG-9	40X114	17	2314
3LG-10	40X114	17	1040
3LG-11	40X114	17	896

Wall A			
Mark	Profile	Count	Cut Length

ALG-1	40X114	1	3460
ALG-2	40X114	1	4840
ALG-3	40X114	1	1020
ALG-4	40X114	17	920
ALG-5	40X114	9	3380
ALG-6	40X114	6	300
ALG-7	40X114	3	300
ALG-8	40X114	1	2140
ALG-9	40X114	3	2140
ATL-1	40X114	1	3460
ATL-2	40X114	1	4840

Wall 4			
Mark	Profile	Count	Cut Length

4BL-1	40X57	1	5950
4LG-1 *	40X114	1	837
4LG-2 *	40X114	1	1716
4LG-3 *	40X114	1	2594
4LG-4 *	40X114	1	3473
4LG-5 *	40X114	1	4352
4LG-6 *	40X114	1	5231
4LG-7 *	40X114	1	5950
4LG-8	40X114	2	5950
4LG-9	40X114	9	3078
4LG-10	40X114	9	1332
4LG-11	40X114	8	5950

* Gable - delivered premounted

Wall B			
Mark	Profile	Count	Cut Length

BLG-1	40X114	9	575
BLG-2	40X114	5	4660
BLG-3	40X114	9	520
BLG-4	40X114	17	1175
BLG-5	40X114	1	4660
BLG-6	40X114	8	2635
BTL-1	40X114	1	4660

Kitchener 3 40 (575x760)

List of all items 4





Wall C			
Mark	Profile	Count	Cut Length

CLG-1	40X114	23	3380
CTL-1	40X114	1	3380

Wall D			
Mark	Profile	Count	Cut Length

DLG-1	40X114	1	4840
DLG-2	40X114	7	2020
DLG-3	40X114	5	5838
DLG-4	40X114	5	1418
DLG-5	40X114	6	3260
DLG-6	40X114	7	5780
DLG-7	40X114	6	4540
DLG-8	40X114	1	3460
DTL-1	40X114	1	5980
DTL-2	40X114	1	2320

Log profiles	
Profile	Images4

40X57	
40X114	
40X114	
40X114	
40X114	